

# Department of Procurement & Contract Compliance



**BID #40962**  
**Manhole Covers, Frames & Catch Basin Inlet Grates &  
Frames for WPC**



Unified Government Of Wyandotte County/Kansas City, Kansas  
MINIMUM SPECIFICATIONS AND REQUIREMENTS  
BID #40962

**Manhole Covers, Frames & Catch Basin Inlet Grates & Frames for WPC**

Instructions to Bidders: Bidders must bid the item exactly as specified, or indicate with a description any deviation. If no deviation is indicated, the vendor must produce the item as specified in this bid. Additional sheets may be used if necessary but must reference the specification number.

Reasonable accommodations will be made to qualified individuals with a disability on an as needed basis, provided adequate notice is given by prospective vendors. Solicitations from qualified minority, and women owned businesses, firms and individuals are encouraged by the Unified Government of Wyandotte County/Kansas City, Kansas. This encouragement does not imply preference and all solicitations will be evaluated equally.

**1.0 General Conditions and Requirements:**

- 1.1 All bids shall be submitted in ONE ORIGINAL AND ONE COPY and shall be signed by authorized personnel.

The proposal, bid, and contract shall be submitted for the approval of the Purchasing Agent, who reserves the right to reject any or all bids. The Unified Government of Wyandotte County/Kansas City, Kansas reserves the right to waive minor deviations from the minimum specifications.

- 1.2 All prices shall be quoted F.O.B., Kansas City, Kansas. All sales will be made in accordance with the prices, terms and conditions of the Invitation for Bid and any subsequent term supply and service contract.

- 1.3 Each bid shall be submitted in a sealed envelope, and shall be addressed as follows: **Office of the Unified Clerk, Municipal Office Building, 701 North 7th Street, Room 323, Kansas City, Kansas, 66101. The outside of each sealed envelope containing a bid shall be plainly marked with the Bid Number, the item or project name, and the name and address of the bidder and delivered to the Office of the Unified Clerk no later than 8:45 a.m. Wednesday, June 26, 2024. If this information does not appear, the bid will be rejected. It is the bidder's responsibility to make sure the bid is delivered to the proper place at the proper time.**

- 1.4 The Unified Government of Wyandotte County/Kansas City, Kansas reserves the right to award a contract in whole or in part to the lowest responsive and responsible bidder(s) as provided in section 29-153 of the Procurement Code of the Unified Government of Wyandotte County/Kansas City, Kansas.

- 1.5 The Unified Government of Wyandotte County/Kansas City, Kansas reserves the right to reject any or all bids, in whole or in part, as provided in section 29-178 of the Procurement Code of the Unified Government of Wyandotte County/Kansas City, Kansas, and all Bidders must agree that such rejection shall create no liability on the part of the Unified Government of Wyandotte County/Kansas City, Kansas, because of such rejections; and the filing of any bid in response to this Notice shall constitute an agreement of the Bidder to these conditions.

## MINIMUM SPECIFICATIONS AND REQUIREMENTS (Continued)

---

- 1.6 It is the expressed intent of these specifications to describe the minimum requirements for the above-referenced item(s). **Please note that all bidders are required to document any deviations from these specifications.**
- 1.7 Any items appearing in the manufacturer's regularly published literature and specifications, and listed therein as standard, shall be supplied in the bidder's proposal unless exceeded by these Minimum Specifications and Requirements.
- 1.8 Conditioned bids from the bidder shall be rejected as non-responsive unless the Unified Government identifies conditions in the bid specifications.
- 1.9 The bid shall include all costs associated with the purchase, shipping, delivery, licenses or any other costs associated with the sale of the products or performance of services.
- 1.10 It is the responsibility of each bidder, before submitting a bid, to examine the documents thoroughly, and request written interpretation of clarifications upon discovering any conflicts, ambiguities, errors, or omissions in the bidding documents. Any questions regarding the Minimum Specifications and Requirements shall be directed in writing to the Office of Procurement and Contract Compliance ATTN: Teresa Houchins, Room 649, 701 North 7th Street, Kansas City, Kansas 66101 or e-mailed to [thouchins@wycokck.org](mailto:thouchins@wycokck.org). All questions must be received no later than **11:00 A.M. June 14, 2024**.
- 1.11 The successful bidder must provide proof of workers' compensation insurance prior to contract approval.

The successful bidder must secure the insurance coverage required by the Unified Government. The coverage must be satisfactory to the Unified Government. A bidder's failure to provide evidence of such insurance coverage is a material breach and grounds for withdrawal of the award or termination of the contract.

### **2.0 Occupational Taxes and Contract Award:**

- 2.1 A contract for the item(s) will be awarded, in whole or in part, to the lowest responsive and responsible bidder(s) as determined by the minimum specifications and requirements contained herein.
- 2.2 **Prior to contract award, the successful bidder(s) must ensure that all occupational taxes are paid. For information, contact the Unified Government of Wyandotte County/Kansas City, Kansas Business License Division at (913) 573-8780.**
- 2.3 Breach of this covenant may be regarded as a material breach of contract.

### **3.0 Approved Equivalents:**

- 3.1 Bidders shall submit detailed manufacturer's specifications for each item being proposed as an "approved equal". Please note that any use of brand names herein, is for the purpose of describing the standards of quality, performance and desired characteristics of the item(s), and is not intended to limit or restrict competition.

## MINIMUM SPECIFICATIONS AND REQUIREMENTS (Continued)

---

### 4.0 Cooperative Purchasing:

4.1 The bidder agrees to provide products and/or services to any municipality, county, state, governmental public utility, non-profit hospital, educational institute, special governmental agency, and non-profit corporation performing governmental functions that participates as a joint bidder in or is represented by the Mid-America Council of Public Purchasing (MACPP) and/or Mid-America Regional Council (MARC) in the Greater Kansas City Metropolitan Trade Area.

4.2 Sales will be made in accordance with the prices, terms and conditions of the invitation for bid and any subsequent term contract.

4.3 All sales to other jurisdictions will be made on purchase orders issued by that jurisdiction. All receiving, inspection, payments and other procurement administration will be the responsibility of the ordering jurisdiction.

#### 4.4 Administrative Procurement Officer:

Each jurisdiction that is a party to the joint bid has authority to act as an Administrative Procurement Officer with responsibility to issue purchase orders, inspect and receive goods, make payments, and handle disputes involving shipments to the jurisdiction.

#### 4.5 Principal Procurement Officer:

The principal procurement officer is responsible for handling the solicitation and awarding the contract. The principal procurement officer is Teresa Houchins, Department of Procurement & Contract Compliance, Unified Government of Wyandotte County/Kansas City, Kansas.

### 5.0 Required Standard Contractual Terms and Conditions:

The following terms and conditions must be agreed to by the successful Bidder and are hereby made a part of the contract entered into between the Unified Government and the successful Bidder, unless specifically modified in writing:

#### Controlling Provisions:

The terms of these contractual provisions prevail and control over the terms of any other conflicting provision in any other document relating to the Agreement in which this attachment is incorporated.

#### Governing Law:

This Agreement is subject to, governed by, and construed according to the laws of the State of Kansas.

## MINIMUM SPECIFICATIONS AND REQUIREMENTS (Continued)

---

### **Cash Basis Law:**

This Agreement is subject to the Kansas Cash Basis Law, K.S.A. 10-1101 and amendments thereto. Any automatic renewal of the terms of the Agreement shall create no legal obligation on the part of the Unified Government. The Unified Government is obligated only to pay periodic payments or monthly installments under the Agreement as may lawfully be made from (a) funds budgeted and appropriated for that purpose during the Unified Government's current budget year or b) funds made available from any lawfully operated revenue producing source.

### **Disclaimer of Liability:**

The Unified Government shall not hold harmless nor indemnify the Contractor for any liability whatsoever.

### **Anti-Discrimination Requirements:**

During the performance of this Agreement, the Contractor agrees as follows:

- a. The Contractor will not discriminate against any employee or applicant for employment because of race, religion, color, sex, disability, age, national origin, or ancestry. The Contractor will take affirmative action to ensure that applicants are employed, and that employees are treated during employment, without regard to race, religion, color, sex, disability, age, national origin, or ancestry. Such action shall include, but not be limited to, the following: employment, upgrading, demotion, or transfer; recruitment or recruitment advertising; layoff or termination; rates of pay or other forms of compensation; and selection for training, including apprenticeship. The Contractor agrees to post in conspicuous places, available to employees and applicants for employment, notices to be provided by the Unified Government setting forth the provisions of this nondiscrimination clause.
- b. Written notice of award shall be sent to the successful bidder. The successful bidder shall, within ten (10) days from the date of receipt of the notice of award, come into compliance with Article XI of the Unified Government Procurement Code regarding Affirmative Action and Equal Employment Opportunity as required by Sections 18-137 through 18-139 of the Code of Ordinances of the Unified Government of Wyandotte County/Kansas City, Kansas.

Contact Sharon Reed of the Contract Compliance Department located on the 6<sup>th</sup> Floor of the Municipal Office Building, at 913-573-5465 or [sreed@wycokck.org](mailto:sreed@wycokck.org) for more information.

- c. The Contractor will, in all solicitations or advertisements for employees placed by or on behalf of the Contractor state that all qualified applicants will receive consideration for employment without regard to race, religion, color, sex, disability, age, national origin, or ancestry.
- d. The Contractor will cause the foregoing provisions to be inserted in all subcontracts for any work covered by this Agreement so that such provisions will be binding upon each subcontractor.
- e. The Contractor shall assure that it and all subcontractors will implement the certificate of compliance in connection with this Agreement.

## MINIMUM SPECIFICATIONS AND REQUIREMENTS (Continued)

---

- f. If the Contractor shall fail, refuse, or neglect to comply with the terms of these provisions, such failure shall be deemed a total breach of the contract and such Agreement may be terminated, canceled, or suspended, in whole or in part, and the Contractor may be declared ineligible for any further Unified Government contracts for a period of up to one year. Provided that, if a contract is terminated, canceled, or suspended for failure to comply with this section, the Contractor shall have no claims for damages against the Unified Government on account of such termination, cancellation, or suspension or declaration of ineligibility
- g. The Contractor shall assure that it is in compliance and shall maintain sufficient records to document that, under all aspects of this Agreement, it has acted in a manner which is in full compliance with the applicable sections of the Equal Employment section of this Agreement and the following, as applicable: Title VI of the Civil Rights Act of 1964 (42 U.S.C. §2000d *et seq.*), and amendments thereto; Title VII of the Civil Rights Act of 1964 (42 U.S.C. §2000e *et seq.*), and amendments thereto; Title VIII of the Civil Rights Act of 1968 (42 U.S.C. §3601 *et seq.*), and amendments thereto; the Americans with Disabilities Act of 1990 (42 U.S.C. §12101 *et seq.*), and amendments thereto; the Kansas Acts Against Discrimination (K.S.A. 44-1001 *et seq.*), and amendments thereto; Article XI of the Unified Government Procurement Code and Regulations, and amendments thereto; and Sections 18-137 through 18-139 of the Unified Government Code of Ordinances, and amendments thereto. Such records shall at all times remain open to inspection by an individual designated by the Unified Government for such purpose.
- h. The Contractor and the Unified Government, in carrying out this Agreement, shall also comply with all other applicable existing federal, state, and local laws relative to equal opportunity and nondiscrimination, all of which are incorporated by reference and made a part of this Agreement.
- i. The Contractor will be required to conform to Affirmative Action and Equal Employment Opportunity requirements prior to the execution of this Agreement.

### **Termination for Default:**

- a. If the Contractor refuses or fails to perform any of the provisions of this Agreement with such diligence as will ensure its completion within the time specified in this Agreement, or any extension thereof, or commits any other substantial breach of this Agreement, the Procurement Officer may notify the Contractor in writing of the delay or nonperformance and, if not cured in ten days or any longer time specified in writing by the Procurement Officer, such officer may terminate the Contractor's rights to proceed with the Agreement or such part of the Agreement as to which there has been delay or a failure to properly perform.
- b. The Unified Government shall pay the Contractor the costs and expenses and reasonable profit for services performed by the Contractor prior to receipt of the notice of termination; however, the Unified Government may withhold from amounts due the Contractor such sums as the Procurement Officer deems to be necessary to protect the Unified Government against loss caused by the Contractor because of the default.
- c. Except with respect to defaults of subcontractors, the Contractor shall not be in default by reason of any failure in performance of this Agreement in accordance with its terms if the Contractor has notified the Procurement Officer within 15 days of the cause of the delay and

## MINIMUM SPECIFICATIONS AND REQUIREMENTS (Continued)

---

the failure arises out of causes such as acts of God, acts of the public enemy, act of the Unified Government and any other governmental entity in its sovereign or contractual capacity, fires, floods, epidemics, quarantine restrictions, strikes, or other labor disputes. If the failure to perform is caused by the failure of a subcontractor to perform or to make progress, and if such failure arises out of causes similar to those set forth above, the Contractor shall not be deemed to be in default, unless the services to be furnished by the subcontractor were reasonably obtainable from other sources in sufficient time to permit the Contractor to meet the Agreement requirements.

Upon request of the Contractor, the Procurement Officer shall ascertain the facts and extent of such failure, and, if such officer determines that any failure to perform was occasioned by any one or more

of the excusable causes, and that, but for the excusable cause, the Contractor's progress and performance would have met the terms of the Agreement, the time for completion of the Agreement shall be revised accordingly.

- d. If, after notice of termination of the Contractor's right to proceed under the provisions of this clause, it is determined for any reason that the Contractor was not in default under the provisions of this clause, and both the Unified Government and the Contractor agree, the rights and obligations of the parties shall be the same as if the notice of termination had not been issued.
- e. The following acts committed by the Contractor will constitute a substantial breach of the agreement and may result in termination of the agreement.
  - (1) If the Contractor is adjudged bankrupt or insolvent;
  - (2) If the Contractor makes a general assignment for the benefit of its creditors;
  - (3) If a trustee or receiver is appointed for the Contractor;
  - (4) If the Contractor files a petition to reorganize under bankruptcy or applicable laws;
  - (5) If the Contractor repeatedly fails to supply services required under the Agreement;
  - (6) If the Contractor disregards the authority of the Procurement Officer.

Acts other than those specified may constitute substantial breach of this Agreement.

### **Termination for Convenience:**

- a. The Procurement Officer may, when the interests of the Unified Government so require, terminate this contract in whole or in part, for the convenience of the Unified Government. The Procurement Officer shall give written notice of the termination to the Contractor specifying the part of the contract terminated and when termination becomes effective.
- b. The Contractor shall incur no further obligations in connection with the terminated work and on the date set in the notice of termination the Contractor will stop work to the extent specified.

## MINIMUM SPECIFICATIONS AND REQUIREMENTS (Continued)

---

- c. The Procurement Officer shall pay the Contractor the following amounts:
  - (1) All costs and expenses incurred by the Contractor for work accepted by the Unified Government prior to the Contractor's receipt of the notice of termination, plus a reasonable profit for said work.
  - (2) All costs and expenses incurred by the Contractor for work not yet accepted by the Unified Government but performed by the Contractor prior to receipt of the notice of termination, plus a reasonable profit for said work.
- d. Anticipatory profit for work and services not performed by the Contractor shall not be allowed.

### **Disputes:**

- a. All controversies between the Unified Government and the Contractor which arise under, or are by virtue of, this Agreement and which are not resolved by mutual agreement, shall be decided by the Procurement Officer in writing, within 30 days after a written request by the Contractor for a final decision concerning the controversy; provided, however, that if the Procurement Officer does not issue a written decision within 30 days after written request for a final decision, or within such longer period as may be agreed upon by the parties, then the Contractor may proceed as if an adverse decision had been received.
- b. The Procurement Officer shall immediately furnish a copy of the decision to the Contractor by certified mail, return receipt requested, or by any other method that provides evidence of receipt. Any such decision shall be final and conclusive, unless fraudulent, or the Contractor brings an action seeking judicial review of the decision in the Wyandotte County District Court.
- c. The Contractor shall comply with any decision of the Procurement Officer and proceed diligently with performance of this Agreement pending final resolution by the Wyandotte County District Court of any controversy arising under, or by virtue of, this Agreement, except where there has been a material breach of the Agreement by the Unified Government; provided, however, that in any event the Contractor shall proceed diligently with the performance of the Agreement where the Purchasing Director has made a written determination that continuation of work under the contract is essential to the public health and safety.

### **Representations:**

The Contractor makes the following representations:

- a. The price submitted is independently arrived at without collusion.
- b. It has not knowingly influenced and promises that it will not knowingly influence a Unified Government employee or former Unified Government employee to breach any of the ethical standards set forth in Article XII of the Unified Government Procurement Code.

## MINIMUM SPECIFICATIONS AND REQUIREMENTS (Continued)

---

- c. It has not violated, and is not violating, and promises that it will not violate the prohibition against gratuities and kickbacks set forth in section 29-635 (Gratuities and Kickbacks) of the Unified Government Procurement Code.
- d. It has not retained and will not retain a person to solicit or secure a Unified Government contract upon an agreement or understanding for a commission, percentage, brokerage, or contingent fee, except for retention of bona fide employees or bona fide established commercial selling agencies for the purpose of securing business.

### **Interest Payable on Claims:**

Pursuant to section 29-480 (Interest) of the Unified Government Procurement Code, interest on amounts ultimately determined to be due to a contractor of the Unified Government shall be payable at the statutory rate applicable to judgments from the date the claim arose through the date of decision or judgment, whichever is later.

### **Payment of Taxes:**

The Unified Government shall not be responsible for, nor indemnify the Contractor for any federal, state, or local taxes which may be imposed or levied upon the subject matter of this Agreement. The Contractor shall pay the Unified Government occupation tax prior to execution of the Agreement.

### **Representative's Authority to Contract:**

The person signing this Agreement is duly authorized by the Contractor to execute the documents on behalf of the Contractor and to bind the Contractor.

### **Modification of Agreement:**

This Agreement may be modified or amended only in writing executed by both parties.

### **Independent Contractor Relation:**

Nothing in this Agreement shall be construed to create a relationship of employer and employee or principal and agent or any other relationship other than that of independent parties contracting with each other solely for the purpose of carrying out the provisions of this Agreement. Nothing in this Agreement shall create any right or remedies in any third party.

The parties agree that no persons supplied by the Contractor are employees of the Unified Government and that no right of the Unified Government's civil service, retirement, or personnel rules accrue to such persons.

The Contractor shall have the total responsibility for all salaries, wages, workers' compensation insurance, unemployment compensation, bonuses, retirement benefits, withholdings, other benefits, and any taxes and premiums for such items, and the Contractor shall hold the Unified Government harmless with respect thereto.

## MINIMUM SPECIFICATIONS AND REQUIREMENTS (Continued)

---

### **Availability of Records and Audit:**

The Contractor agrees to maintain books, records, documents, and other evidence pertaining to the costs and expenses of the services provided under the Agreement (hereinafter collectively called "records") to the extent and in such detail as will properly reflect all net costs, direct and indirect, of labor, materials, equipment, supplies, and services, and other costs and expenses of whatever nature for which reimbursement is claimed under the provisions of this Agreement. The Contractor agrees to make available at the offices of the Unified Government at all times during the term of the Agreement any of the records for inspection, audit, or reproduction by any authorized representative of the Unified Government. Except for documentary evidence delivered to the offices of the Unified Government, the Contractor shall preserve and make available to persons designated by the Unified Government its records for a period of three years from the date of the termination of the Agreement or until all audit questions have been resolved, whichever period of time is longer.

### **Assignment:**

Neither the Contractor nor the Unified Government shall, sell, transfer, assign, or otherwise dispose of any rights or obligations created by this Agreement without the written consent of the other party.

If Contractor's ownership is converted into, merges or consolidates with, or sells or transfers substantially all of its assets or business to another corporation, the resulting corporation or the corporation to which such sale or transfer has been made shall notify the Unified Government of such conversion, merger, consolidation, sale, or transfer and shall become the Contractor hereunder only if the Unified Government specifically so consents in writing. Contractor agrees to notify the Unified Government of any changes in the membership of the general partners of the Contractor within a reasonable time after such change.

### **No Limit of Liability:**

Nothing in this Agreement shall be construed to limit the Contractor's liability to the Unified Government as such liability may exist by or under operation of law.

### **Tax Clearance for City and Local Governments:**

The local governments of Jackson County, Missouri, Johnson County, Kansas and the Unified Government of Wyandotte County/Kansas City, Kansas (collectively the "Local Governments"), have agreed to help enforce each other's tax laws to insure that taxpayer funded contracts are performed by Contractors in compliance with the tax laws of the Local Governments. Contractor agrees that Contractor shall be in compliance with the tax laws of the Local Governments throughout the term of this contract any contract renewals and that proof of Contractor's compliance with the tax laws of the Local Governments shall be a condition precedent to Parties making each of the first payment under their subsequent contract or any contract renewal.

The selected Contractor may obtain the Unified Government tax clearance letter from Procurement and Contract Compliance Department and authorize the County to obtain the Clearance letters from the Local Governments, dated not more than ninety (90) days from the date of submission.

## MINIMUM SPECIFICATIONS AND REQUIREMENTS (Continued)

---

### Payment Options:

A virtual payment option is now available. If you would like to learn more about this payment option, Contact Lonia Green, Accounts Payable, 913-573-5138

### Indemnification:

Contractor shall indemnify, defend, and hold the Unified Government of Wyandotte County/Kansas City,

### Ownership of Materials:

All property rights, including publication rights, in all interim, draft, and final reports and other documentation, including machine-readable media, produced by the Contractor in connection with the work pursuant to this Agreement, shall be in the Unified Government.

## **6.0 Insurance Requirements:**

The Contractor must secure the insurance coverage required by the Unified Government. The coverage must be satisfactory to the Division of Risk Management. The Contractor's failure to provide evidence of such insurance coverage is a material breach and grounds for withdrawal of the award or termination of the contract.

Liability insurance coverage shall be considered as primary and not as excess insurance. The carrier(s) shall provide ten (10) days written notice to the Unified Government by registered mail prior to any modification, cancellation, nonrenewal, or other change in coverage. The Contractor shall provide the Unified Government with Certificates of Insurance concerning the requirements listed.

The policies must be effective prior to the commencement of work and must remain in force until termination of the work under this contract. In the event of interruption of coverage for any reason, all work under the contract shall cease and shall not resume until coverage has been restored.

If at any time during the term of this contract, or any extension thereof, any required policies of insurance should expire or are cancelled, it will be the responsibility of the Contractor to furnish to the Unified Government a Certificate of Insurance indicating renewal or an acceptable replacement of the expiring policy prior to expiration or cancellation date so that there will be no lapse in any coverage.

The Unified Government shall be named as an additional insured. The following minimum coverage is generally required of Contractors providing services:

Worker's Compensation	
Applicable State	Statutory
General Liability	
Each Occurrence	\$500,000.00
Aggregate	\$1,000,000.00

## MINIMUM SPECIFICATIONS AND REQUIREMENTS (Continued)

---

1. Additional Insured shall read exactly as follows:

“The Unified Government of Wyandotte County and Kansas City, Kansas shall be named as additional insured with respect to the work performed for this contract: (Bid #B40962, Manhole Covers, Frames & Catch Basin Inlet Grates & Frames for WPC).”

2. Cancellation Clause shall read exactly as follows:

Should any of the above-described policies be cancelled before the expiration date thereof, the issuing company will mail ten (10) days’ prior written notice to the certificate holder.

3. Certificate Holder:

Provide “B40962, Manhole Covers, Frames & Catch Basin Inlet Grates & Frames for WPC” in the comments area of certificate. Address all certificates to the Unified Government Wyandotte County/Kansas City, Kansas – Purchasing Division, 701 N 7<sup>th</sup> Street – Room 649, Kansas City, KS 66101. Fax 913-573-5444 Office 913-573-5440.

### **7.0 Minimum Bid Specifications:**

The Unified Government of Wyandotte County/Kansas City, Kansas Public Works Department/Water Pollution Control Division is interested in receiving bids for manhole covers.

Materials shall be delivered to Sewer Maintenance, 51 Market Street, Kansas City, Kansas, other than the rare occasion that the delivery will be at a specific location within the Wyandotte County boundaries.

#### **(1) Catch Basin Inlet Grate & Frame: (Attachment A)**

- Two Grates Required for Each Frame
- The Grates Shall be Reversible in the Frame
- Total Open Area for Both Grates Shall be 378 Square Inches
- Material: Cast Gray Iron ASTM A-48, Class 35B
- Finish: No Paint
- Weight: 370 LBS
- Dimensions: See Attachment A

#### **(2) Manhole Rings & Covers: (Attachment B & C)**

- Logo: UNIFIED GOVERNMENT Wyandotte County/Kansas City, Kansas per Attachment B
- STORM, SANITARY or WATER Inserts per Attachment C
- Made in USA on Top of Ring
- Julian Heat Date
- 1” Lifting Hole in Every Other Gusset, 6 Gussets 5/8<sup>th</sup> Taper to 3/8”
- Two Concealed Pick Slots
- Furnished with Machined Horizontal Bearing Surface
- Material: Cast Gray Iron ASTM A-48, Class 35B
- Finish: No Paint
- Weight: Frame 225 LBS-Cover 135 LBS
- Dimensions: See Attachment B

## MINIMUM SPECIFICATIONS AND REQUIREMENTS (Continued)

---

### 8.0 Agreement Term and Adjustments:

- Prices bid shall remain fixed and firm based upon the original proposal for the first year of the contract.
- The Unified Government reserves the right to renew the Agreement by the procurement officer giving written notice of renewal to the contractor at least fifteen (15) days before this Agreement is to expire. Agreement term is for one (1) year from date of execution. The Agreement may be extended four (4) one (1) year extensions.
- A one-time economic adjustment shall be allowed for each one-year extension to the Agreement after the initial one-year contract period. This economic adjustment may not exceed the Consumer Price Index (CPI) for the previous twelve-month period.

### 9.0 Bid Deadlines and Delivery Instructions:

- Sealed bids must be addressed and delivered to: **Bid #40962, Manhole Covers, Frames & Catch Basin Inlet Grates & Frames for WPC**, Office of the Unified Clerk, Unified Government of Wyandotte County/Kansas City, Kansas, 3rd Floor, **Room 323**, Municipal Office Building, 701 North 7th Street, Kansas City, Kansas, 66101 **NO LATER THAN 8:45 a.m., Wednesday, June 26, 2024.**

It is the offeror's responsibility to ensure **bids** are received by the closing date and time. Delays in mail delivery or any other means of transmittal, including couriers or agents of the issuing entity shall not excuse **late bid** submissions. Offerors shall be responsible for actual delivery of the response to the appropriate office identified in the document.

### 9.0 Signatures:

- No bid will be considered unless signed with the autograph signature of an officer authorized to bind the vendor.

---

**Company Name**

---

**Authorized Representative**

---

**Mailing Address**

---

**Signature**

**Date**

---

**City, State, Zip Code**

---

**Title**

---

**Phone Number**

---

**Fax Number**

---

**Federal Tax ID #**

---

**E-Mail Address**

## MINIMUM SPECIFICATIONS AND REQUIREMENTS (Continued)

---

### Bid Price Sheet

If this Manhole Cover, Frames, and Catch Basin Inlet Grates & Frames bid is accepted, the undersigned, familiar with the specifications and conditions affecting the cost of proposed product agrees to enter into an agreement with the Unified Government of Wyandotte County, Kansas City, Kansas in the form of these documents for the submitted sum, in the time stated and following all terms and conditions.

Orders will placed on an "AS-NEEDED" basis, with quantities specified at time of order placement.

	<b>Unit Cost (Each)</b>
Catch Basin Inlet Grates	\$
Catch Basin Inlet Grate Frames	\$
Manhole Covers	\$
Manhole Rings	\$
Delivery Charge	\$

Company Name \_\_\_\_\_

Address \_\_\_\_\_

City, St Zip \_\_\_\_\_

Contact \_\_\_\_\_

Contact Phone \_\_\_\_\_

Contact Email \_\_\_\_\_

MINIMUM SPECIFICATIONS AND REQUIREMENTS (Continued)

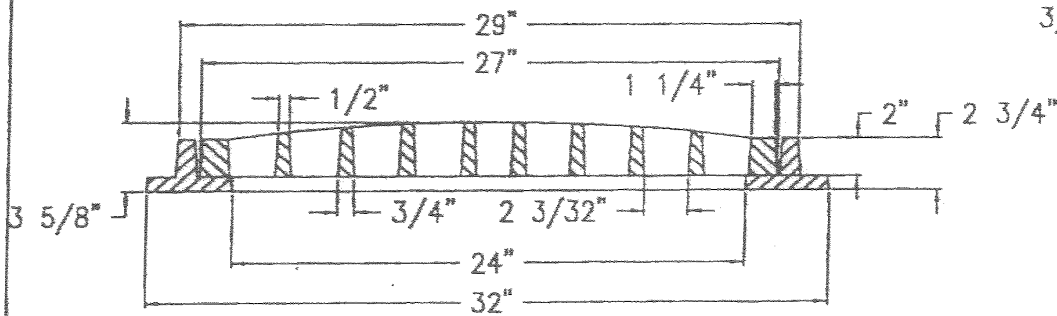
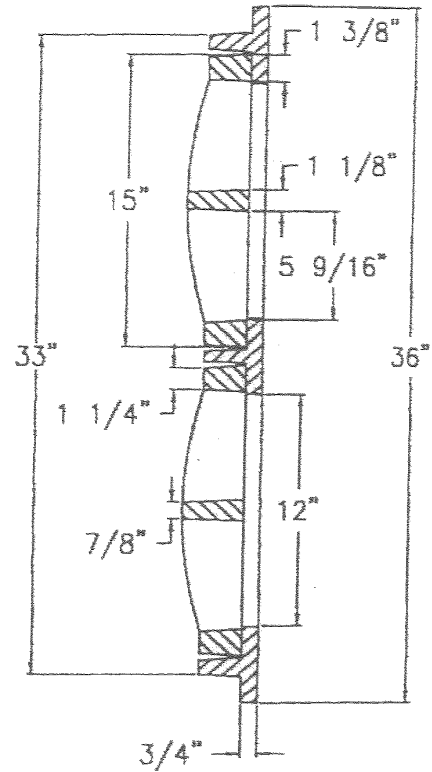
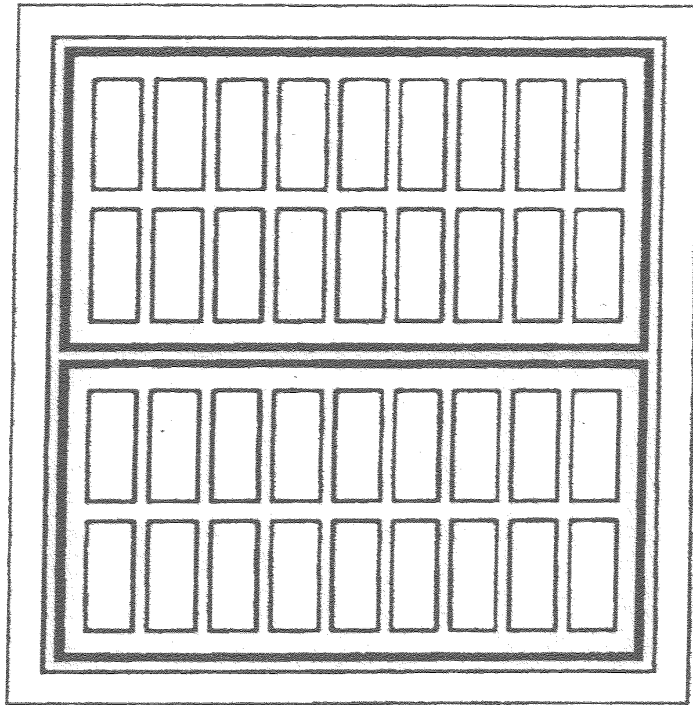

NOTE:

1. TWO GRATES REQUIRED FOR EACH FRAME.
2. THE GRATES ARE REVERSIBLE IN THE FRAME.
3. TOTAL OPEN AREA FOR BOTH GRATES IS 378 SQUARE INCHES.

MATERIAL: CAST GRAY IRON ASTM A-48,  
CLASS 35B

FINISH: NO PAINT

WEIGHT: 370 LBS.

ATTACHMENT A

CATCH BASIN INLET GRATE & FRAME

MINIMUM SPECIFICATIONS AND REQUIREMENTS (Continued)

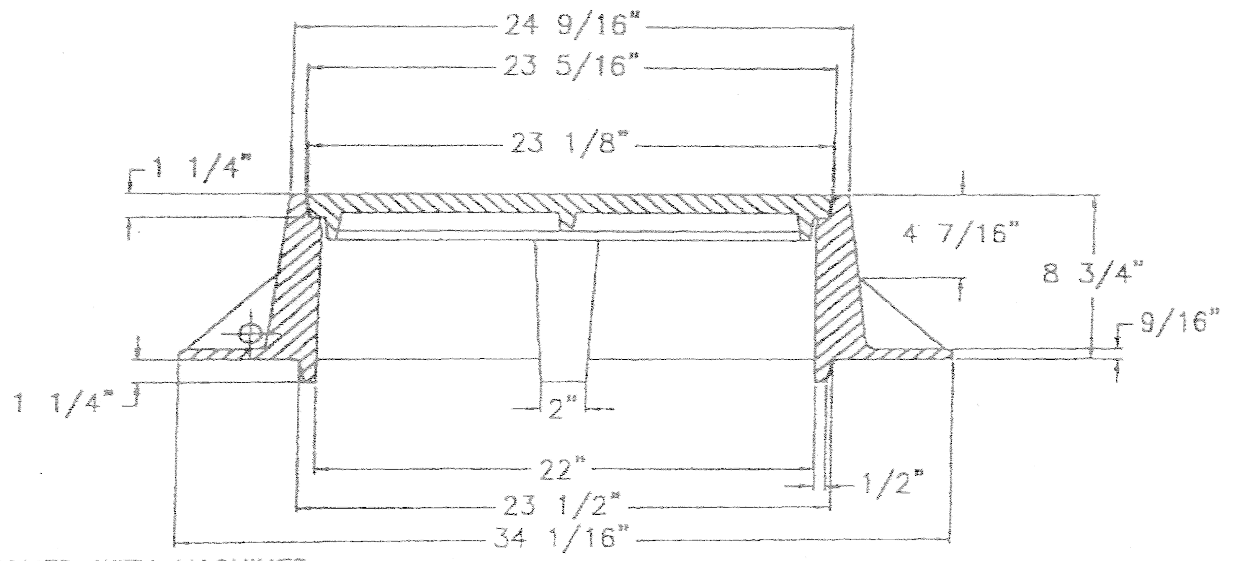
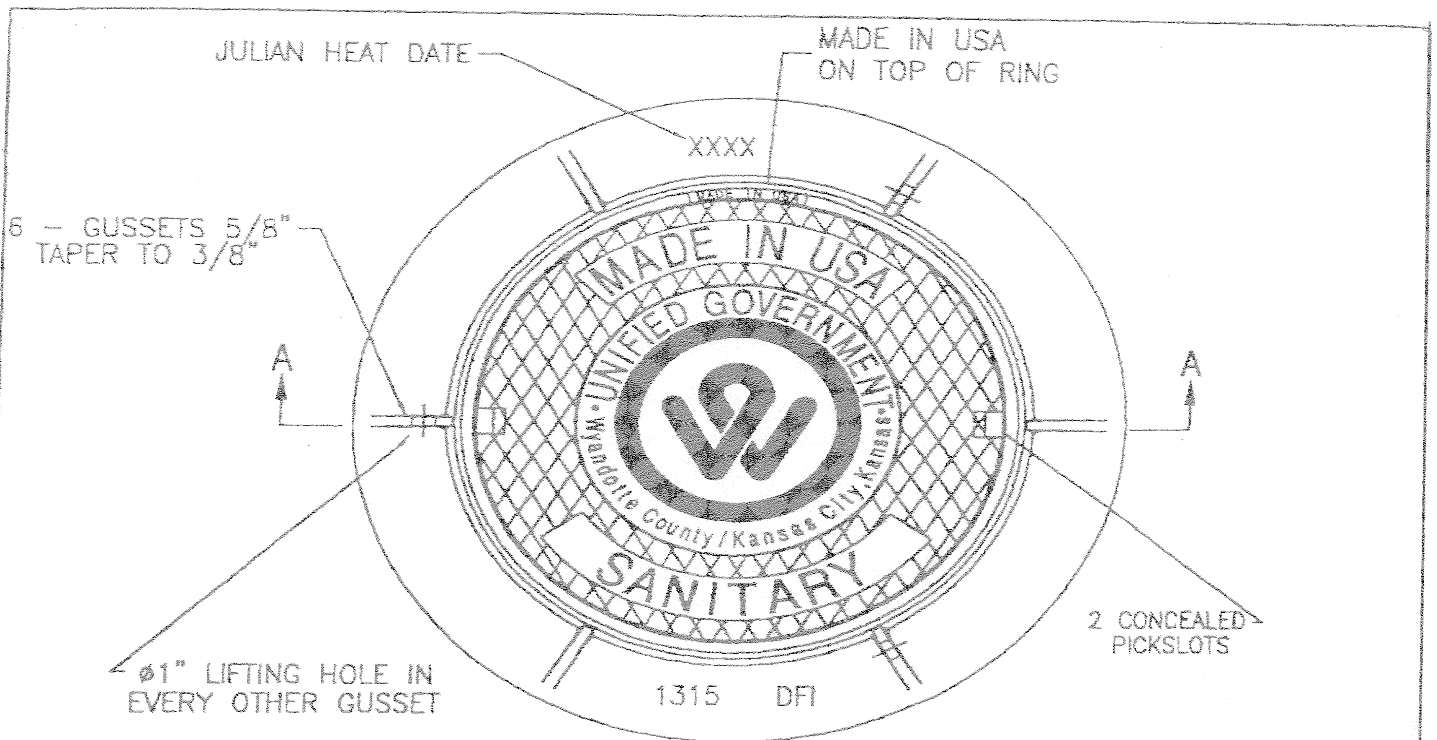

NOTE:  
 1. FURNISHED WITH MACHINED HORIZONTAL BEARING SURFACE.

MATERIAL:	CAST GRAY IRON ASTM A-48, CLASS 35B
FINISH:	NO PAINT
WEIGHT:	FRAME 225 LBS. COVER 135 LBS.

**ATTACHMENT B**  
 MANHOLE RING & COVER

**MINIMUM SPECIFICATIONS AND REQUIREMENTS (Continued)**

**ATTACHMENT C**

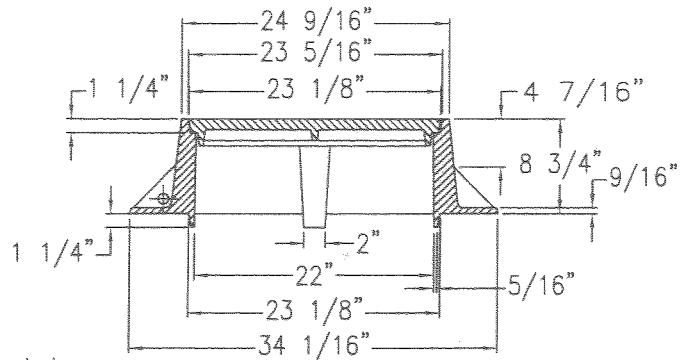
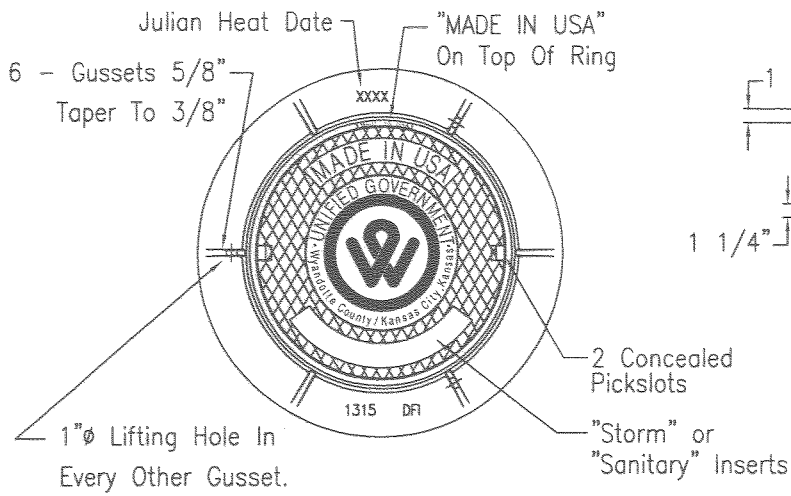

**NOTE:**

1. Furnished With Machined Horizontal Bearing Surface.  
 Material: Gray Cast Iron ASTM A-48, Class 35B.  
 Weight: Frame 225 Lbs.  
 Cover 135 Lbs.  
 Finish: No Paint

S... MANHOLE COVER (SANITARY)